

Technical Data

- Airgap per side : 4,5 mm – 5 mm
- Max. wear rail/ jaw per side : 5 mm
- Ambient temperature : - 20 °C to + 50 °C
- Closing time setting : 5 s to 30 s
- Opening time : 10 s to 15 s
- Operating cycles : 10 to 20 times per day
- Motor voltage : 230/ 400 V, 50/ 60 Hz, S3 – 30 %
- Valve voltage : 24 V

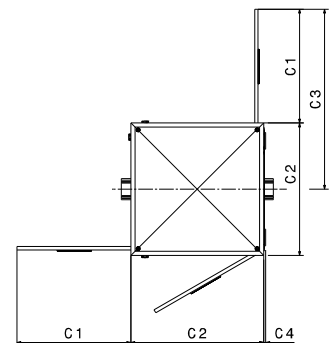

- *¹ At max. rail size acc. information B4. Deviations from the standard upon request.
- *² Crane rail acc. DIN, other types of crane rails upon request
- *³ Quantity and strength grade of the screws.

○ RB 200-50	: 6x M20 – 10.9	$M_a = 580 \text{ Nm}$, $\mu = 0,14$
○ RB 400-50	: 8x M24 – 10.9	$M_a = 1000 \text{ Nm}$, $\mu = 0,14$
○ RB 600-50	: 8x M30 – 10.9	$M_a = 2000 \text{ Nm}$, $\mu = 0,14$
○ RB 800-50	: 10x M30 – 10.9	$M_a = 2000 \text{ Nm}$, $\mu = 0,14$
○ RB 1000-50	: 12x M30 – 10.9	$M_a = 2000 \text{ Nm}$, $\mu = 0,14$

Holding force and dimensions

Typ:	Holding force		Weight [kg]	B1 [mm]	B2 [mm]	B3 ⁺¹ min. [mm]	B4 ⁺² [mm]	C1 [mm]	C2 [mm]	C3 [mm]	C4 [mm]	d ⁺³ [mm]	H1 [mm]	H2 [mm]	H3 [mm]	H4 [mm]	L1 [mm]	L2 [mm]	L3 [mm]	L4 [mm]	
	[kN]	[kN]																			
μ [-]	0,25	0,5																			
RB 200-50	100	200	520	820	540	270	A65 A75 A100	649	785	1042	7	22	925	842	40	320	808	100	110	30	
RB 400-50	200	400	760	865	580	300	A75 A100	694	830	1109	17	26	997	949	40	350	863	80	105	30	
RB 600-50	300	600	1190	955	650	380	A100 A120 A150	784	920	1244	15	33	1157	1116	40	400	951	90	115	35	
RB 800-50	400	800	1550	995	700	380	A120 A150	824	960	1304	15	33	1210	1167	40	450	990	80	120	40	
RB 1000-50	500	1000	1850	1035	780	400	A120 A150	864	1030	1394	0	33	1248	1210	40	530	1046	80	120	40	

Description and technical data

- The rail clamps are released electro-hydraulically and close with spring force.
- When the rail clamp is closed, the compression springs press on the pressure straps (knee lever system) in the middle, between the two clamp levers, thereby generating the clamping force.
- Via this system, the ratio of the lever system is increased as the jaw/ rail wears, thereby more or less compensating for the decreasing spring force. Within the permissible wear range of the jaws/ rail, the clamping force is nearly constant.
- The rail clamp is guided on the rail by the flange wheels; this ensures the mechanics of the rail clamp is afforded horizontal freedom of movement (float) of ± 30 mm and a vertical freedom of movement (float) of ± 20 mm in the rail clamp housing. In the direction parallel to the rails, the clamp is guided with minimal play (5 mm per direction of travel) in the rail clamp housing.
- Lockable protection cover made of stainless steel and three inspections doors.
- The release of the rail clamp occurs via integrated hydraulic power pack (HPU) with hydraulic cylinder. In emergency stop operation, the rail clamp can be released via hand pump connected to the HPU.
- The functional status of the rail clamp is monitored with the signals of the limit switches: „Brake open“, „Brake closed“, and „wear end“.