

limit switch:
„released“

directional limit switch
„right“

directional limit switch
„left“

12 mm nominal distance
brake „released“

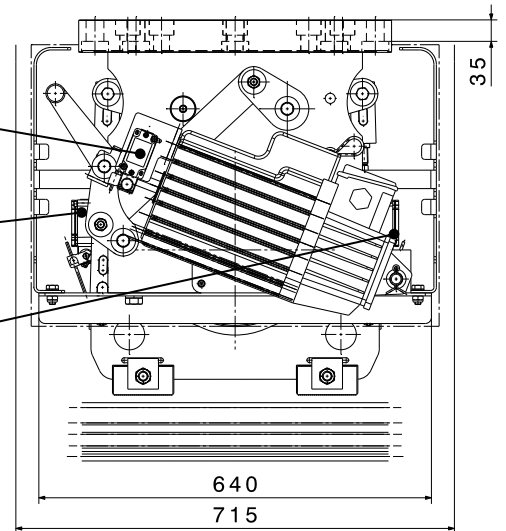

inspection window

8 bores $\varnothing 29$ for
cylinder-head screws
DIN912-M27-10.9
 $M_A = 1250 \text{ Nm}$, $\mu = 0,14$

ventilation

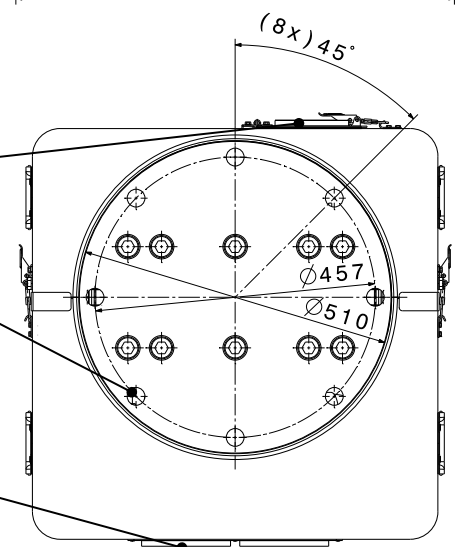

Technical Data:	Information:
Bi-directionally acting, static storm brake for gantry travel	The crane can travel between 50 mm and 100 mm before the rail brake is engaged
Max. holding force $F_H = 225 \text{ kN}$, it is generated by a wedge clamped between clamp wheel and crane rail	Nominal gap between rail and released brake show is 12 mm
Released with Eldro thruster	Max. permissible deviation of rail height is +/- 6 mm
Thruster with lowering valve and c-spring	The rail brake is designed for installation under gantry travel cross-beam
With manual release lockable in released position	
Field replaceable brake shoes	
Brake shoes hardened and on the are of support it is carried out with sprockets	
Limit switch for brake "released"	
Limit switch for directional indication	
Option A: steel version powdered (80 μm), fittings, inspection window, ventilation of stainless steel; weight approx. 395 kg	
Option B: stainless steel version powdered (80 μm), fittings, inspection window, ventilation of stainless steel; weight approx. 395 kg	