

Brake Disc	Absolute dimension L5 in regard to coupling- and disc- size									
	38	42	48	55	65	75	90	100	110	125
ØD1xB1	L5	L5	L5	L5	L5	L5	L5	L5	L5	L5
Ø 200x20	29,5									
Ø 250x20	29,5	31,5	31,5							
Ø 315x20		31,5	31,5	35,5	35,5	38,5				
Ø 400x20				35,5	35,5	38,5	39,5			
Ø 500x30				45,5	45,5	48,5	49,5	54,5	55,5	59,5
Ø 630x30						48,5	49,5	54,5	55,5	59,5
Ø 710x30								54,5	55,5	59,5
Ø 800x30									55,5	59,5

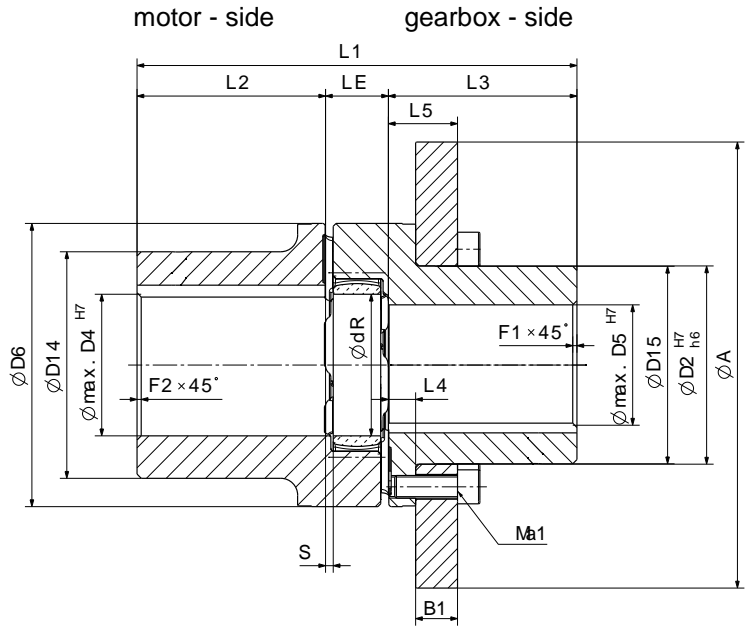

Brake Disc	Weight, moment of inertia and max. allowed braking torque in regards to coupling- and disc size										
	38	42	48	55	65	75	90	100	110	125	
T _{Br max} Nm	430	790	890	1000	1800	3840	7200	9900	14400	20000	
ØD1xB1	kg kgm ²	kg kgm ²	kg kgm ²	kg kgm ²	kg kgm ²	kg kgm ²	kg kgm ²	kg kgm ²	kg kgm ²	kg kgm ²	max Drehzahl n _{max} in min ⁻¹
Ø 200x20	4,6 0,024										5200
Ø 250x20	7,4 0,060	7,4 0,060	7,1 0,060								4200
Ø 315x20		11,8 0,152	11,7 0,152	11,5 0,151	11,2 0,151	10,8 0,149					3300
Ø 400x20				19,0 0,394	18,7 0,394	18,3 0,392	17,3 0,388				2600
Ø 500x30				45,0 1,440	44,6 1,441	44,2 1,443	42,6 1,435	41,8 1,433	40,5 1,422	38,5 1,403	2100
Ø 630x30						71,3 3,643	69,8 3,633	68,9 3,633	67,6 3,616	65,7 3,601	1650
Ø 710x30								88,7 5,866	87,5 5,846	85,5 5,832	1450
Ø 800x30									112,6 9,444	110,7 9,432	1300

Type ALC-AS	T _{kn} Nm	T _{kmax} Nm	ØD4 ØD5 pilot bore	ØD4 max	ØD5 max	ØD6	ØD2 H7/h6	ØD14	ØD15	ØdR	L1	L2	L3	L4	LE	S	F1 F2 x45°	DIN 912 -10.9	Z	Ma1	I kgm ²		G kg
																					w/o brake disc		
38	325	650	-	42	30	80	50	70	49,5	38	144	60	60	9,5	24	3	1,5	M8	8	35	0,002	2,3	
42	450	900	-	50	38	95	60	80	59,5	46	166	70	70	11,5	26	3	1,5	M8	12	35	0,004	3,5	
48	525	1050	-	55	42	105	68	90	67,5	51	178	75	75	11,5	28	3,5	2	M8	12	35	0,007	5	
55	685	1370	18	65	48	120	78	105	77,5	60	200	85	85	15,5	30	4	2	M10	8	69	0,012	7,5	
65	940	1880	18	70	55	135	92	115	91,5	68	235	100	100	15,5	35	4,5	2,5	M10	12	69	0,025	11	
75	1920	3840	28	80	65	160	106	135	105,5	80	270	115	115	18,5	40	5	2,5	M12	15	120	0,055	18	
90	3600	7200	38	100	85	200	140	160	139,5	100	315	135	135	19,5	45	5,5	3	M16	15	295	0,146	32	
100	4950	9900	38	110	95	225	156	180	155	113	350	150	150	24,5	50	6	3	M16	15	295	0,256	44	
110	7200	14400	48	125	110	255	176	200	175	127	375	160	160	25,5	55	6,5	3	M20	15	580	0,454	61	
125	10000	20000	48	140	125	290	204	230	203	147	430	185	185	29,5	60	7	3	M20	15	580	0,885	91	

When selecting the coupling assembly, setting and maintenance instructions have to be observed. Other disc diameters upon request. Other dimensions upon request. Individual balancing of coupling components available upon request. Axial fixing of coupling hub possible with set- screw above the key upon request. Weight and inertia indicated for max. bore ØD4 and Ø D5.