

Hebel zweiteilig!
hier im montierten Zustand!
two-part lever!
shown in assembled state!

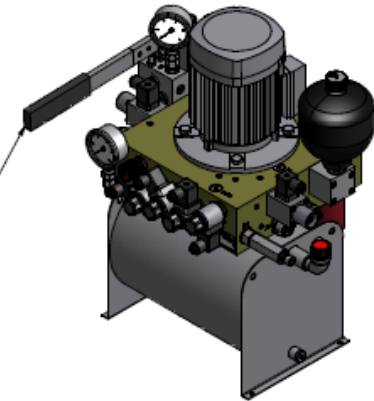

Technical Data

- Weight without oil-filling
ca. 70 kg
- Tank volume
10 l
- Ambient temperature ranges
-15°C ... +50°C in standard version
-40°C ... +40°C in low temperature version
-15°C ... +75°C in high temperature version
- humidity
≤ 90%
- recommended operating fluid
HLP Hydraulic oil acc DIN51524-T2
- for standard version: HLP Synth 32
- others version: upon request
- protection class
Standard = IP55, optional IP65
- max. no. of operating cycles per hour
200
- motor
rotating clockwise when looking from ventilator:
supply voltage range
50 Hz / 380-420 V
60 Hz / 440-480 V
- valve voltages
P = 24 V DC (Standard)
V = 115 V AC ; 50/60 Hz (optional)
W = 230 V AC ; 50/60 Hz (optional)
(others upon request)
- valve capacity per valve
standard: 35 l/min at Δp 4 bar
optional: 70 l/min at Δp 10 bar
- mounting position of HPU
horizontal

Alterations reserved

Sibre Siegerland-Bremsen GmbH – Auf der Stücke 1-5 – D-35708 Haiger, Germany
Tel.: +49 2773 94000 – Fax: +49 2773 9400-10 – e-mail: info@sibre.de – www.sibre.de

P:\CATALOGUES\EN WIND GENERATOR CATALOGUE\DOC-Version 2011-04-26\EN-120 HPU Wind Turbine 2012-02.doc

Pressure switch		Pressure relieve valve setting (DBV)	Release pressure	Pump capacity	Motor power
min	max				
bar		bar	bar	l/min	kW
customized solution					

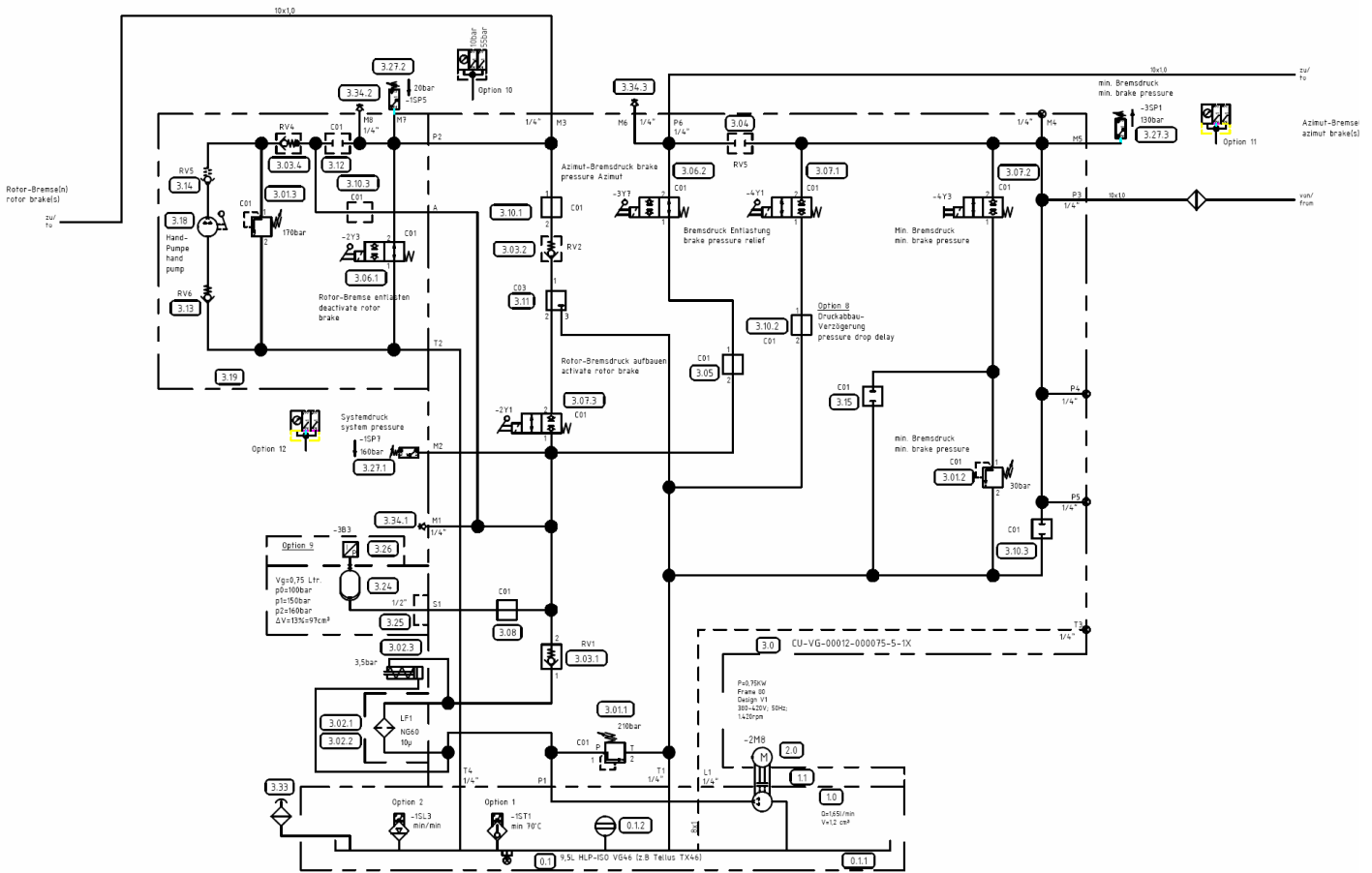

Suitable for				
ABT 75 G	ABT 90 G	ABT 75 S	ABT 90 S	ABT 120 S
ABS 75 G	ABS 75 FC	ABS 120 FC	ABS 75 G-R	ABS 90 G-R
ABT 75 S-R	ABT 90 S-R			
SHI 75 FC	FSB 75 FC	FSB 101 - 107 FC		
RLH 80				